

INTERNATIONAL CHRISTMAS MARKET

NOV. 16-18 | NOV. 23-25 | NOV. 30 - DEC. 2

The Spruce Meadows International Christmas Market presented by Telus offers everything a holiday shopper could desire — all in one, unique and beautiful venue. Spruce Meadows sees approximately 175,000 visitors to the grounds over the Christmas period. Come and be apart of the atmosphere and sell your product to the thousands of visitors attending each day.

Seasonal decorations and entertainment,
274 indoor & outdoor booths available.

Event Space starting at just **\$731!**



INTERNATIONAL CHRISTMAS MARKET

NOV. 16-18 | NOV. 23-25 | NOV. 30 - DEC. 2

The International Christmas Market is an integral part of the unique and diverse seasonal celebrations at Spruce Meadows. The International Christmas Market features four interconnected halls plus vendors in the Horizons Pavilion, Courtyard and Founders Plaza. Families enjoy yuletide fun and entertainment; voices of roaming carollers soar in the crisp air.

* NEW APPLICANTS

Preference will be given to new vendor applications who also book a booth in and attend one of the other 2018 Spruce Meadows trade shows.

Book your Spruce Meadows International Christmas Market booth today and join us in a celebration of the Christmas Season unlike any other!

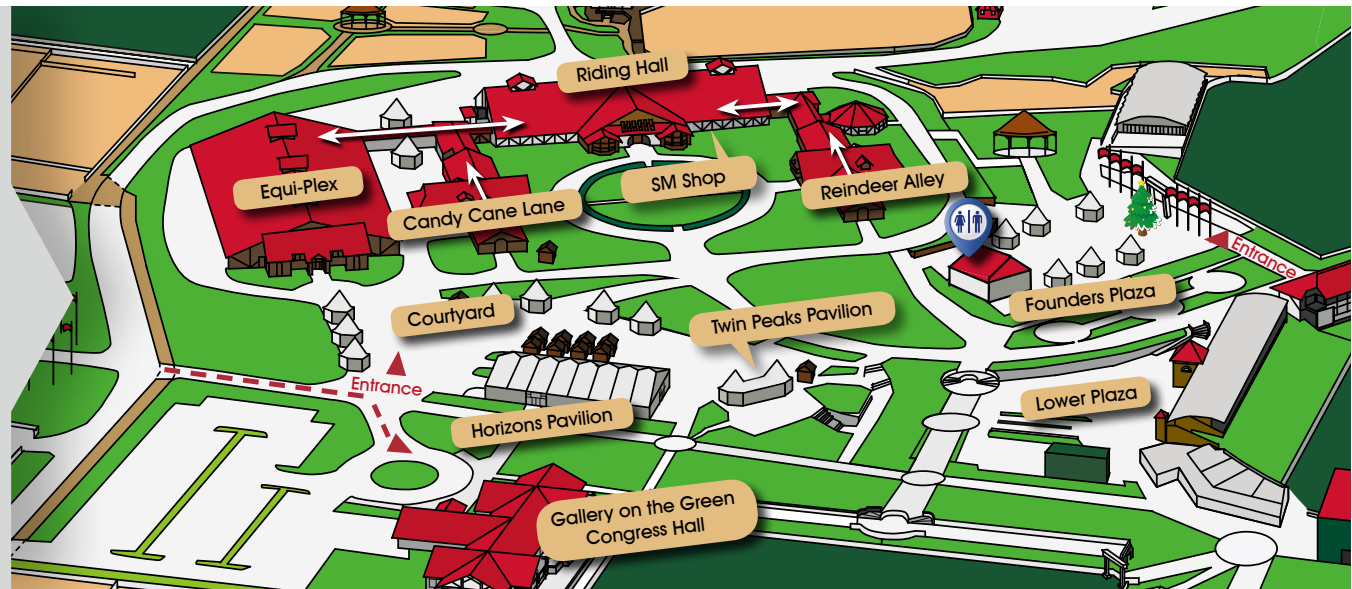

IMPORTANT INFORMATION

All food vendors are limited to pre-packaged sales and sampling only.

Please be aware that sub-letting of booth space is absolutely NOT allowed.

Spruce Meadows has a very strict rule regarding sight lines within all venues. Vendors are not permitted to block, in any way, sight lines along aisles. Any vendor disrespecting this rule will be asked to remove all product displayed in this area.

INTERNATIONAL CHRISTMAS MARKET

NOV. 16-18 | NOV. 23-25 | NOV. 30 - DEC. 2

OUTDOOR HÖCKER TENT

• \$6,352 (3 WEEKENDS ONLY)

A heated and fully enclosed hexagonal structure that offers exceptional product display flexibility.

Total structure space - 700 sq.ft.

- (2) - Skirted 2' x 8' Table
- (4) - 1,000 watt, 110 VAC Outlet
- (1) - 3' x 3' Sign
- (4) - Chairs

Prices do not include administration fee and 5% G.S.T.

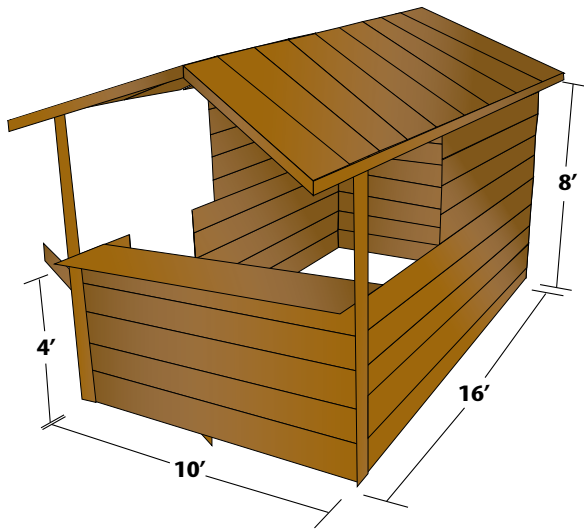

OUTDOOR GARDENHAUS

• \$1,793 (3 WEEKENDS ONLY)

Gardenhauses are placed within our outdoor courtyard, with fire pits, lights, and Internationally themed decor.

- (1) - 10' x 16' Outdoor Gardenhaus
- (1) - Skirted 2' x 8' Table
- (2) - 1,000 watt, 110 VAC Outlet
- (1) - Sign
- (2) - Chairs

Prices do not include administration fee and 5% G.S.T.



Höcker structures offer vendors a high quality, high visibility platform to showcase many products.

INTERNATIONAL CHRISTMAS MARKET

NOV. 16-18 | NOV. 23-25 | NOV. 30 - DEC. 2

HORIZONS PAVILION

The Horizons Pavilion can accommodate 41 draped booths in a large, light environment. The Horizons Pavilion is centrally located to provide maximum exposure for all vendors.

** Please be aware that the exhibit and booth layouts of this venue may change without notice and booth preference cannot be guaranteed. The floor plan shown here is proposed with the best information at hand at time of publication. Spruce Meadows reserves the right to change, without notice, the floor layout as registrations, building code and aesthetics dictate.*

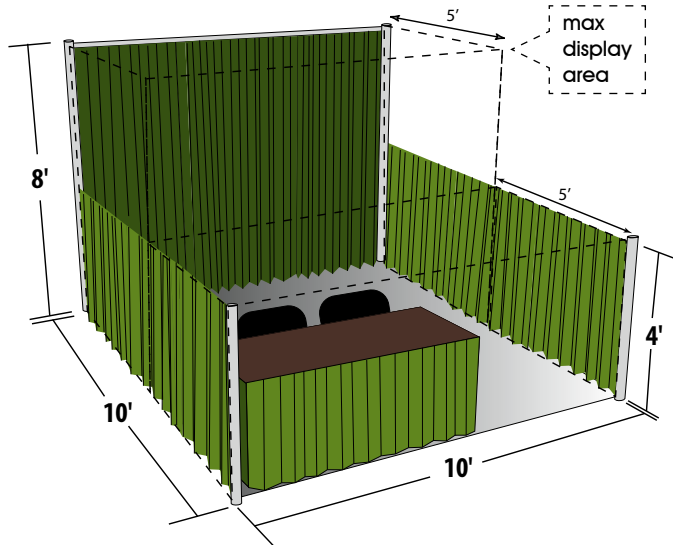
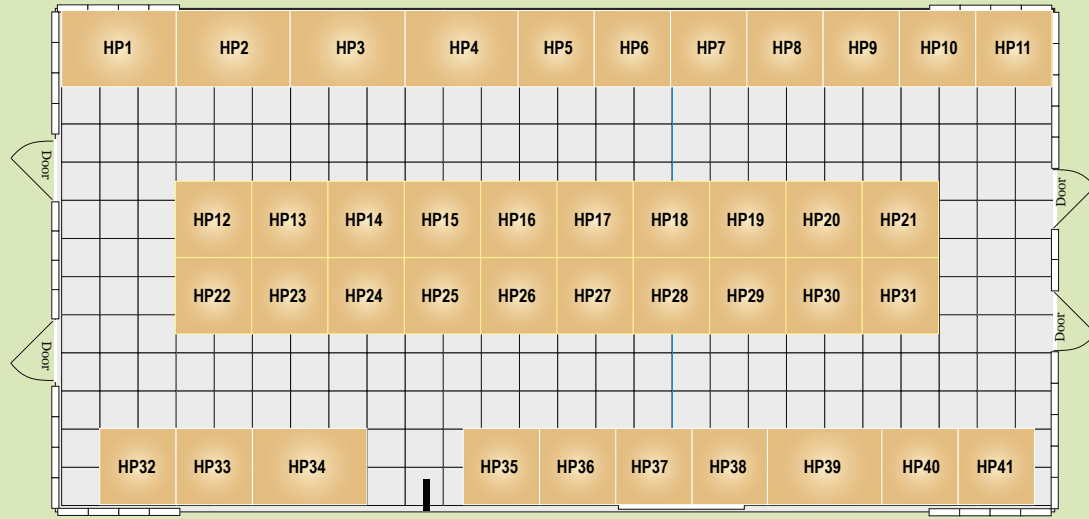

DRAPED BOOTH

in the Horizons Pavilion

\$2,194 (ALL 3 WEEKENDS)

- (1) - 10' x 10' draped booth
- (1) - Skirted 2' x 8' Table
- (1) - 1,000 watt, 110 VAC Outlet
- (1) - 8' x 1' Sign (2) - Chairs

Prices do not include administration fee and 5% G.S.T.



IMPORTANT INFORMATION

All food vendors are limited to pre-packaged sales and sampling only.

Please be aware that sub-letting of booth space is absolutely NOT allowed.

Spruce Meadows has a very strict rule regarding sight lines within all venues. Vendors are not permitted to block, in any way, sight lines along aisles. Any vendor disrespecting this rule will be asked to remove all product displayed in this area.

INTERNATIONAL CHRISTMAS MARKET

NOV. 16-18 | NOV. 23-25 | NOV. 30 - DEC. 2

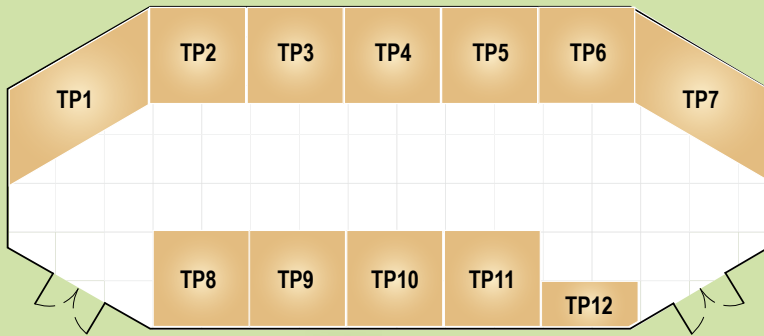

TWIN PEAKS PAVILION

The Twin Peaks Pavilion building can accommodate 12 draped booths in a large, light, centrally located environment.

** Please be aware that the exhibit and booth layouts of this venue may change without notice and booth preference cannot be guaranteed. The floor plan shown here is proposed with the best information at hand at time of publication. Spruce Meadows reserves the right to change, without notice, the floor layout as registrations, building code and aesthetics dictate.*

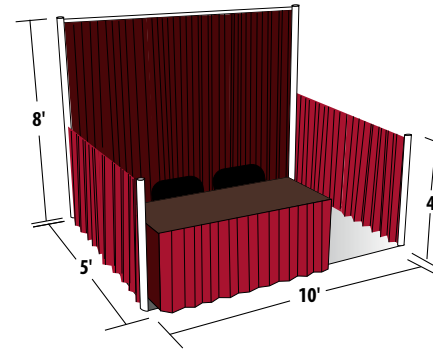

DRAPED BOOTH
\$1,463 (ALL 3 WEEKENDS)

TP12

- (1) - 10' x 5' Draped Booth
- (1) - Skirted 2' x 8' Table
- (1) - 1,000 watt, 110 VAC Outlet
- (1) - 8' x 1' Sign (2) - Chairs

Prices do not include administration fee and 5% G.S.T.

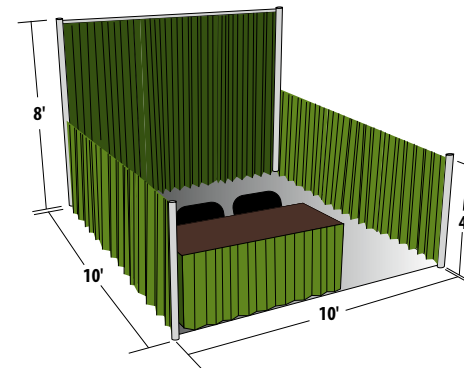

DRAPED BOOTH
\$2,194 (ALL 3 WEEKENDS)

TP2 to TP6 / TP8 to TP11

- (1) - 10' x 10' Draped Booth
- (1) - Skirted 2' x 8' Table
- (1) - 1,000 watt, 110 VAC Outlet
- (1) - 8' x 1' Sign (2) - Chairs

Prices do not include administration fee and 5% G.S.T.

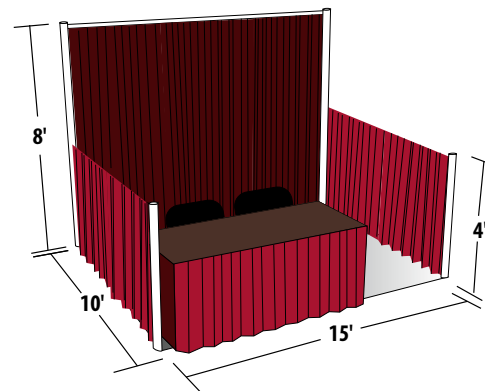

DRAPED BOOTH
\$2,887 (ALL 3 WEEKENDS)

TP1 & TP7

- (1) - 10' x 15' Draped Booth
- (1) - Skirted 2' x 8' Table
- (1) - 1,000 watt, 110 VAC Outlet
- (1) - 8' x 1' Sign (2) - Chairs

Prices do not include administration fee and 5% G.S.T.



INTERNATIONAL CHRISTMAS MARKET

NOV. 16-18 | NOV. 23-25 | NOV. 30 - DEC. 2

EQUI-PLEX LAYOUT

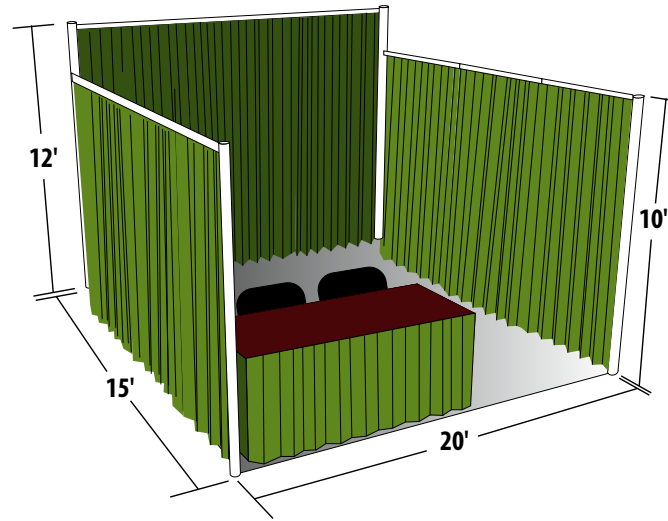
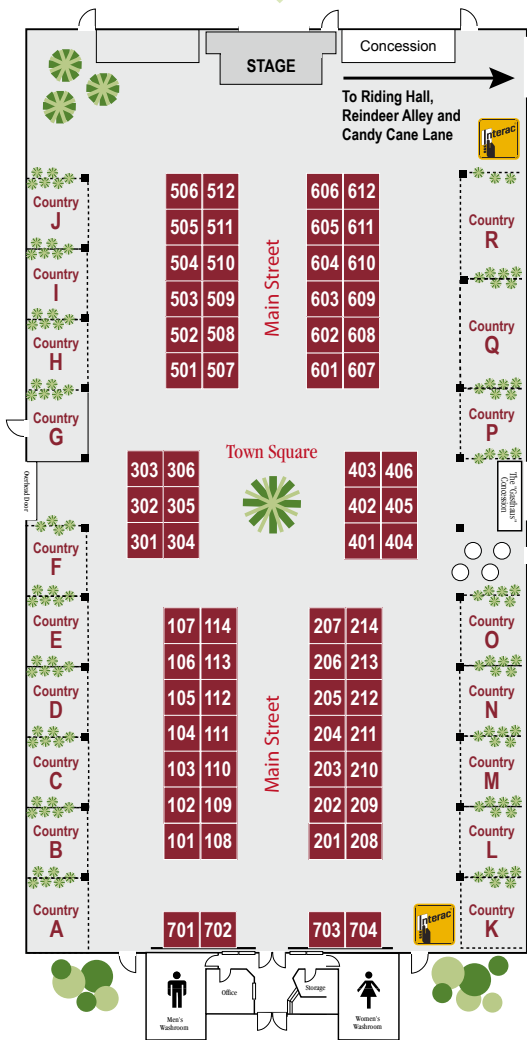

COUNTRY BOOTH • \$4,620

Equi-Plex (ALL 3 WEEKENDS)

- (1) - 20' x 15' Draped Booth
- (2) - Skirted 2' x 8' Table
- (2) - 1,000 watt, 110 VAC Outlet
- (1) - 30" x 15' Sign
- (2) - Chairs

Prices do not include administration fee and 5% G.S.T.

CANOPY BOOTH • \$2,667

Equi-Plex (ALL 3 WEEKENDS)

- (1) - 10' x 10' Booth w/ Canopy
- (1) - Skirted 2' x 8' Table
- (1) - 1,000 watt, 110 VAC Outlet
- (1) - 8' x 1' Sign
- (2) - Chairs

Prices do not include administration fee and 5% G.S.T.

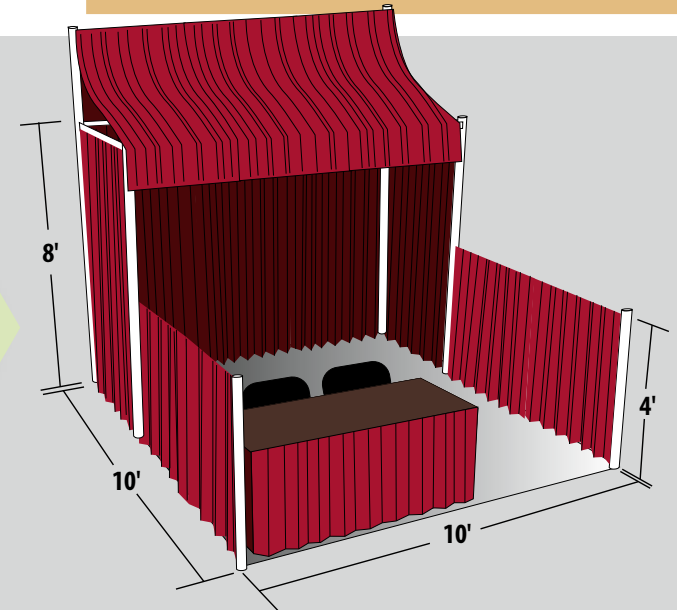

INTERNATIONAL CHRISTMAS MARKET

NOV. 16-18 | NOV. 23-25 | NOV. 30 - DEC. 2

RIDING HALL LAYOUT

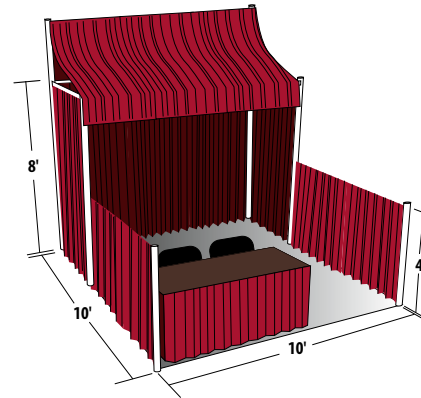
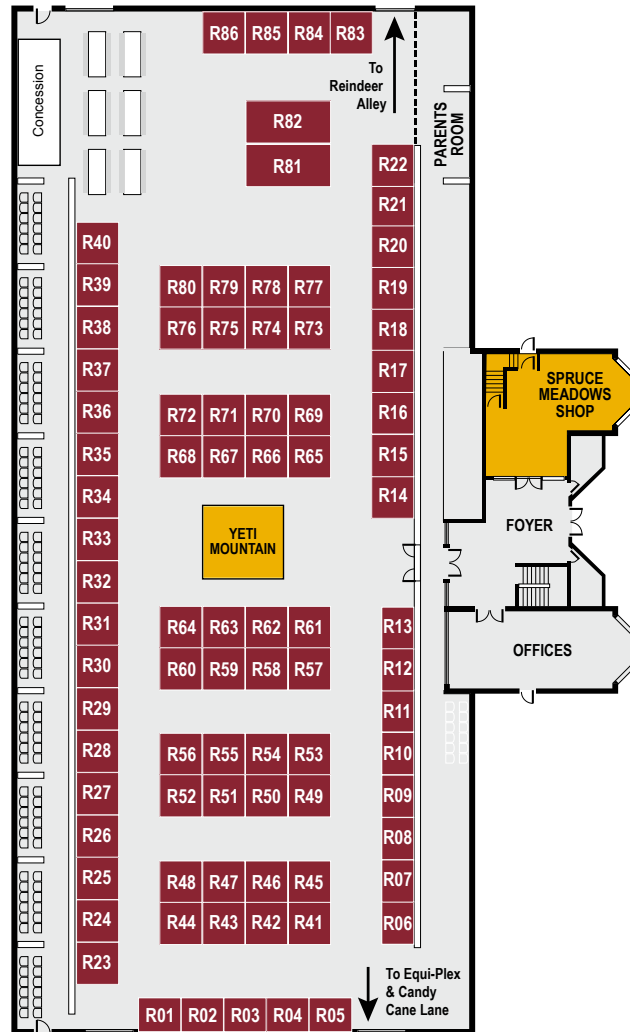

CANOPY BOOTH
\$2,667 (ALL 3 WEEKENDS)

R41 to R80

- (1) - 10' x 10' Booth w/ Canopy
- (1) - Skirted 2' x 8' Table
- (1) - 1,000 watt, 110 VAC Outlet
- (1) - 8' x 1' Sign (2) - Chairs

Prices do not include administration fee and 5% G.S.T.

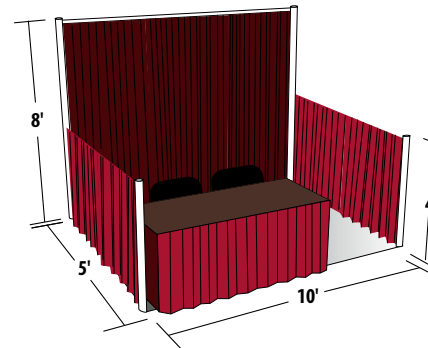

DRAPED BOOTH
\$1,732 (ALL 3 WEEKENDS)

R01 to R13

- (1) - 10' x 5' Draped Booth
- (1) - Skirted 2' x 8' Table
- (1) - 1,000 watt, 110 VAC Outlet
- (1) - 8' x 1' Sign (2) - Chairs

Prices do not include administration fee and 5% G.S.T.

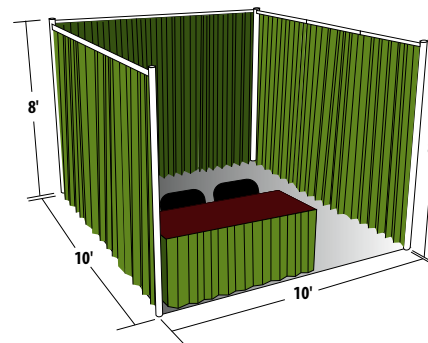

DRAPED BOOTH
\$2,194 (ALL 3 WEEKENDS)

R14 to R40

- (1) - 10' x 10' Draped Booth
- (1) - Skirted 2' x 8' Table
- (1) - 1,000 watt, 110 VAC Outlet
- (1) - 8' x 1' Sign (2) - Chairs

Prices do not include administration fee and 5% G.S.T.

INTERNATIONAL CHRISTMAS MARKET

NOV. 16-18 | NOV. 23-25 | NOV. 30 - DEC. 2

CANDY CANE LANE LAYOUT

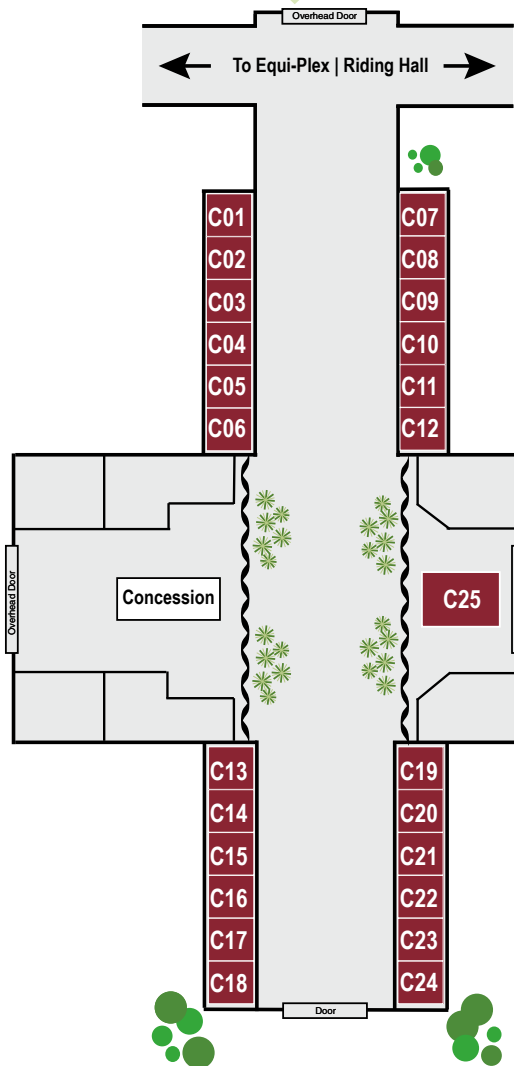

HARDWALL BOOTH

• \$1,908 (ALL 3 WEEKENDS)

- (1) - 12' x 12' Cleaned Stall
- (1) - Skirted 2' x 8' Table
- (1) - 1,000 watt, 110 VAC Outlet
- (1) - 8' x 1' Sign
- (2) - Chairs

Prices do not include administration fee and 5% G.S.T.

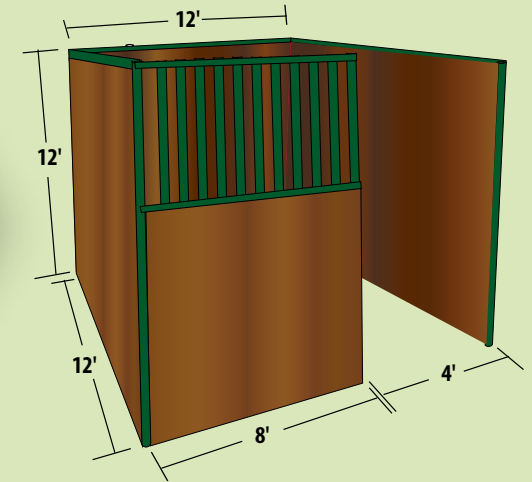

INTERNATIONAL CHRISTMAS MARKET

NOV. 16-18 | NOV. 23-25 | NOV. 30 - DEC. 2

REINDEER ALLEY LAYOUT

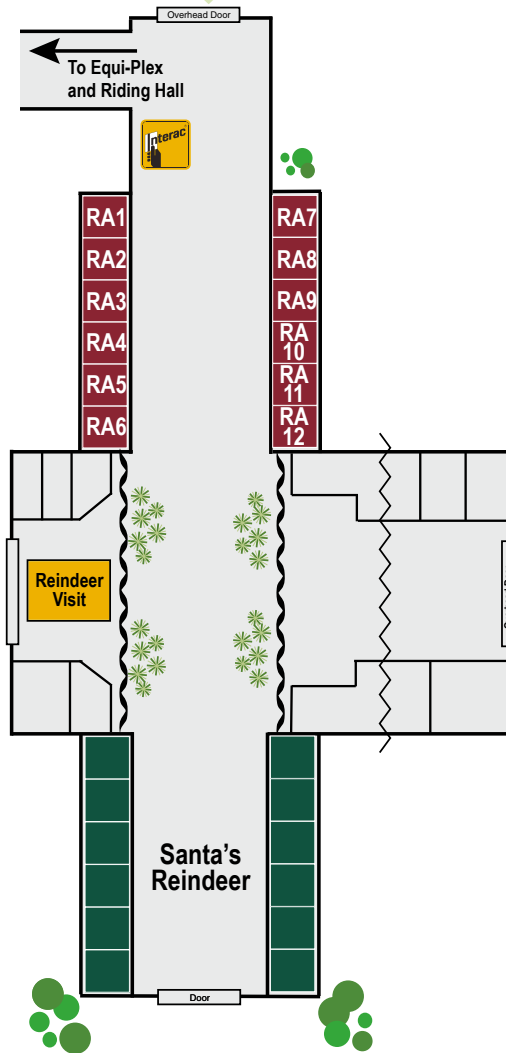

HARDWALL BOOTH

• \$1,908 (ALL 3 WEEKENDS)

- (1) - 12' x 12' Cleaned Stall
- (1) - Skirted 2' x 8' Table
- (1) - 1,000 watt, 110 VAC Outlet
- (1) - 8' x 1' Sign
- (2) - Chairs

Prices do not include administration fee and 5% G.S.T.

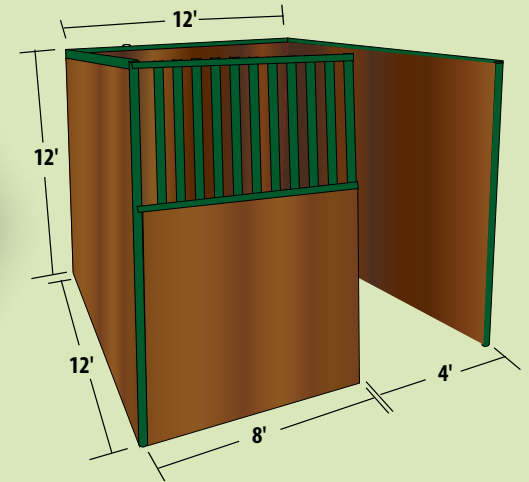

INTERNATIONAL CHRISTMAS MARKET

NOV. 16-18 | NOV. 23-25 | NOV. 30 - DEC. 2

GALLERY ON THE GREEN CONGRESS HALL LAYOUT

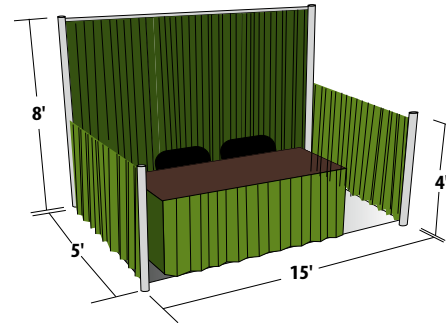

DRAPED BOOTH

\$865 (1 WEEKEND)

\$1,731 (2 WEEKENDS)

\$2,597 (3 WEEKENDS)

CH13 to CH15

- (1) - 5' x 15' Draped Booth
- (1) - Skirted 2' x 8' Table
- (1) - 1,000 watt, 110 VAC Outlet
- (1) - 8' x 1' Sign (2) - Chairs

Prices do not include administration fee and 5% G.S.T.

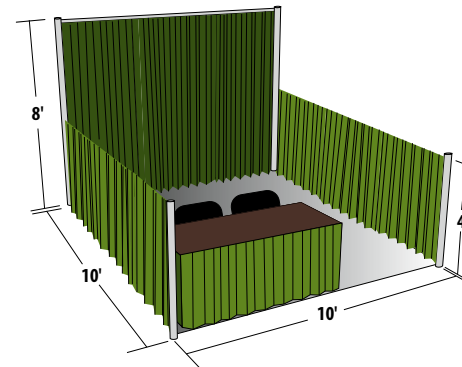

DRAPED BOOTH

\$731 (1 WEEKEND)

\$1,463 (2 WEEKENDS)

\$2,194 (3 WEEKENDS)

- (1) - 10' x 10' Draped Booth
- (1) - Skirted 2' x 8' Table
- (1) - 1,000 watt, 110 VAC Outlet
- (1) - 8' x 1' Sign (2) - Chairs

Prices do not include administration fee and 5% G.S.T.

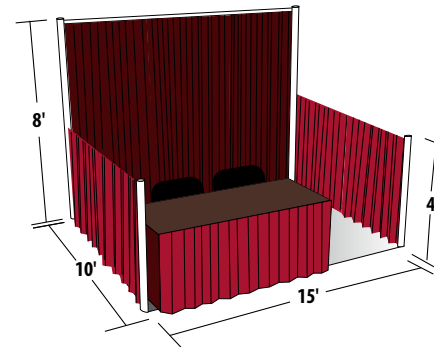

DRAPED BOOTH

\$962 (1 WEEKEND)

\$1,925 (2 WEEKENDS)

\$2,887 (3 WEEKENDS)

- (1) - 10' x 15' Draped Booth
- (1) - Skirted 2' x 8' Table
- (1) - 1,000 watt, 110 VAC Outlet
- (1) - 8' x 1' Sign (2) - Chairs

Prices do not include administration fee and 5% G.S.T.

INTERNATIONAL CHRISTMAS MARKET

NOV. 16-18 | NOV. 23-25 | NOV. 30 - DEC. 2

RETURNING VENDOR:

Booth renewal & payment deadline to retain SAME booth space from last year is **March 16**.

NEW VENDOR:

Applications for new vendors may be submitted online at any time prior to the event - subject to booth availability and product suitability.

BOOTH CANCELLATION DEADLINE

To receive a full refund of International Christmas Market booth fees, minus \$100 admin fee, booth must be cancelled no later than **October 1**. No refund of fees if cancelled after this date.

MOVE IN / SET-UP/ HOURS

LARGE ITEM MOVE-IN AND SET-UP

Monday, Nov. 12 • 10:00am - 5:00pm
Tuesday, Nov. 13 • 10:00am - 5:00pm
Wednesday, Nov. 14 • 10:00am - 5:00pm
Thursday, Nov. 15 • 10:00am - 8:00pm
Thursday, Nov. 22 • 10:00am - 8:00pm
Thursday, Nov. 29 • 10:00am - 8:00pm

EXHIBIT HOURS - INDOOR BOOTHS

Fridays • 10:00am - 8:00pm
Saturdays • 10:00am - 7:00pm
Sundays • 10:00am - 5:00pm

EXHIBIT HOURS - COURTYARD, REINDEER ALLEY & CANDY CANE LANE

Fridays • 9:30am - 8:00pm
Saturdays • 9:30am - 7:00pm
Sundays • 9:30am - 5:00pm

EXHIBIT OFFICE HOURS

Fridays • 8:30am - 8:30pm
Saturdays • 8:30am - 7:30pm
Sundays • 8:30am - 5:30pm

MOVE-OUT

Sundays • 5:00pm - 11:00pm

*No vehicles on grounds until public have left.
Approximately 6:30 pm*

SECURITY ON DUTY

Security is operational during closed hours on Thursday, Friday and Saturday nights, and 24 hours from Sunday, November 18 (starting from 6:00 pm) to Friday, November 23 and Sunday, November 25 to Friday, November 30 (ending 9:30 am).

QUESTIONS?

CONTACT INFO:

Nickola: 403.974.4249 | Lisa: 403.974.4263

E-mail: exhibit.programs@sprucemeadows.com

Website: www.sprucemeadows.com/exhibitor

Fax: 403.974.4266

